

# Data sheet series 587/190/390 Super short designs

9.06 driveshaft with length compensation,  
super short design

## Series 587

Design

9.06

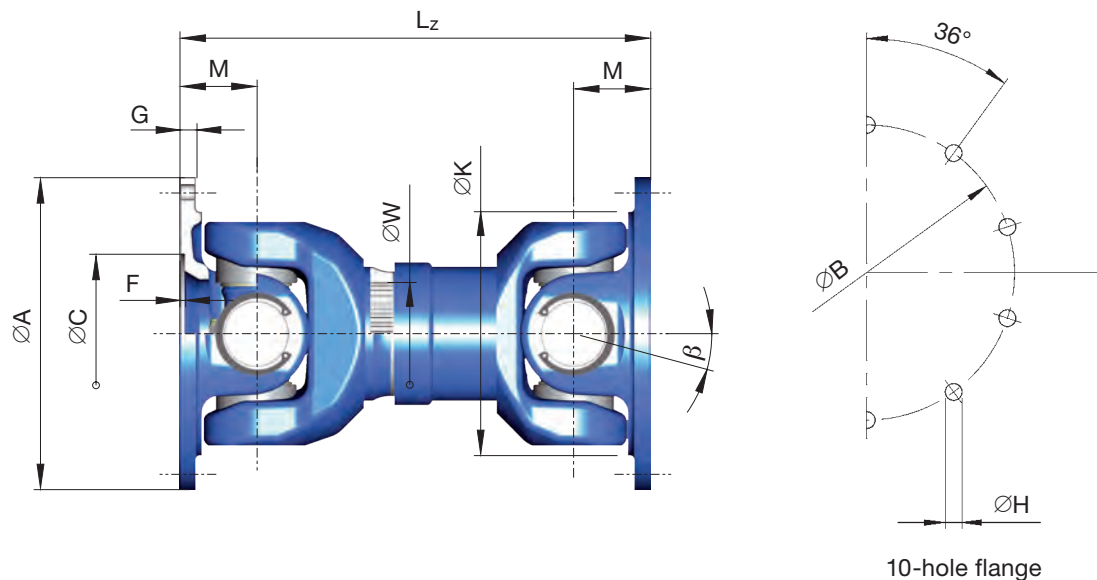

Shaft size		587.50	190.55	390.60	190.65	390.70
T <sub>CS</sub>	kNm	43	33	60	68	130
T <sub>DW</sub>	kNm	13	11	23	25	53
L <sub>c</sub>	-	1,84	7	58,5	166	510
β	γ	5	5	5	5	5
A	mm	275	305	348	360	405
K	mm	215	250	285	315	350
B ± 0,1 mm	mm	248	275	314	328	370
C H7	mm	140	140	175	175	220
F <sup>1)</sup>	mm	4,5	5,5	6	6	6,5
G	mm	15	15	18	18	22
H + 0,2 mm	mm	14,1	16,1	18,1	18,1	20,1
I <sup>2)</sup>	-	10	10	10	10	10
M	mm	68	80	90	100	108
W DIN 5482/5480	mm	90 x 2,5	100 x 94	115 x 2,5	130 x 3	150 x 3

T<sub>CS</sub> = Functional limit torque\*  
Yield torque 30% over T<sub>CS</sub>  
T<sub>DW</sub> = Reversing fatigue torque\*  
L<sub>c</sub> = Bearing capacity factor\*

\* See specifications of driveshafts.  
β = Maximum deflection angle per joint  
1) Effective spigot depth  
2) Number of flange holes

# Data sheet series 587/190/390 Super short designs

## Series 190/390

### Design

9.06

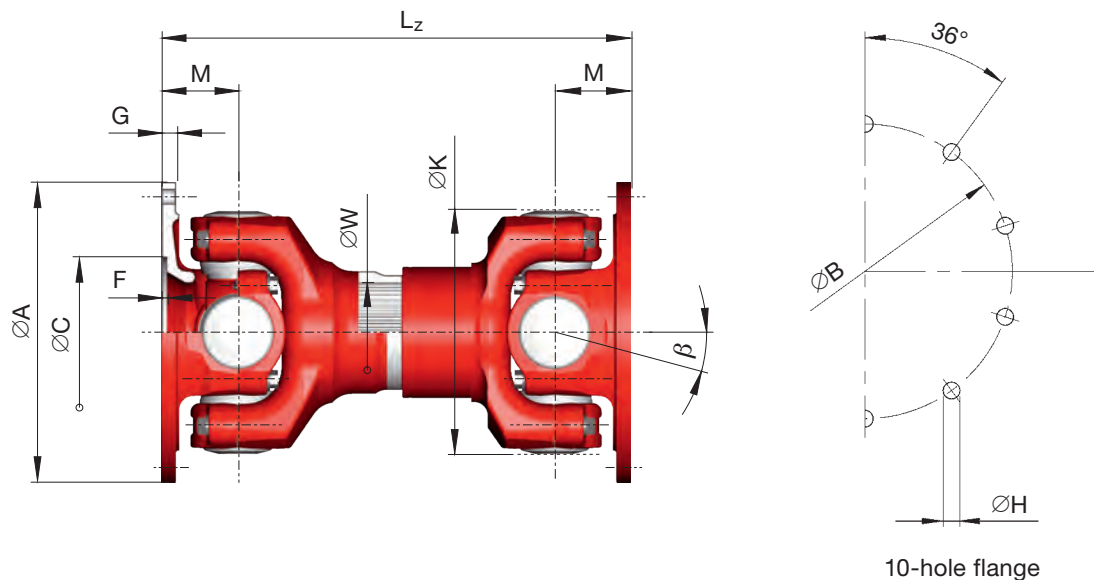

Design	Shaft size		587.50	190.55	390.60	190.65	390.70
<b>9.06</b>	L <sub>z</sub>	mm	415	495	545	600	688
	L <sub>a</sub>	mm	40	40	80	40	80
	G	kg	60	98	131	169	252
	J <sub>m</sub>	kgm <sup>2</sup>	0,33	0,624	1,250	2,286	3,455

L<sub>z</sub> = Shortest compressed length  
 L<sub>a</sub> = Length compensation  
 L<sub>z</sub> + L<sub>a</sub> = Maximum operating length

G = Weight of shaft  
 J<sub>m</sub> = Moment of inertia