

BUTTON OPERATED VALVES

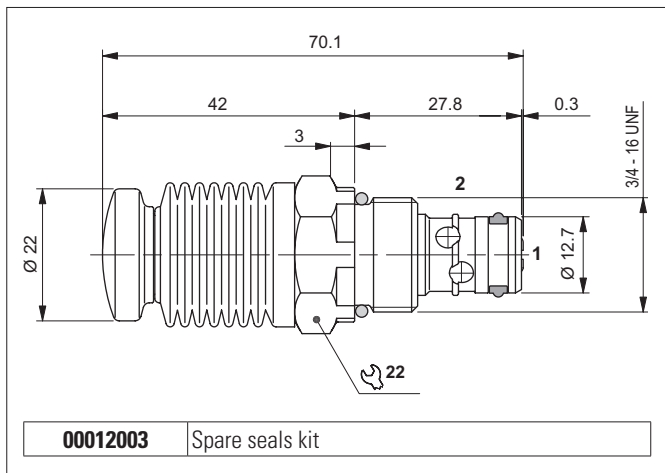

The direct acting, normally closed 2-way 2 position directional valve with manual control is used for emergencies. It is opened by pressing the button. The bi-directional tapered poppet is in tempered and ground steel. The valve body is in galvanised steel.

HYDRAULIC FEATURES

Max. working pressure	300 bar
Max. Flow	30 l/min
Max. Leakage (0 ÷ 20 drops/min)	0 ÷ 1 cm ³ /min
Hydraulic fluid	DIN 51524 Mineral oils
Fluid viscosity	10 ÷ 500 mm ² /s
Fluid temperature	-25°C ÷ 75°C
Ambient temperature	-25°C ÷ 60°C
Max. contamin. level class with filter	ISO 4406:1999 - class 19/17/14
Weight	0.107 kg
Tightening torque	25 ÷ 30 Nm
Cavity (3/4 - 16 UNF)	CD018006 (See section 17)

Valve housings see section 14.

HYDRAULIC SYMBOL

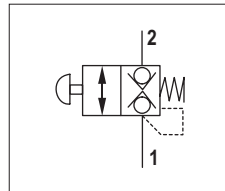

PRESSURE DROPS

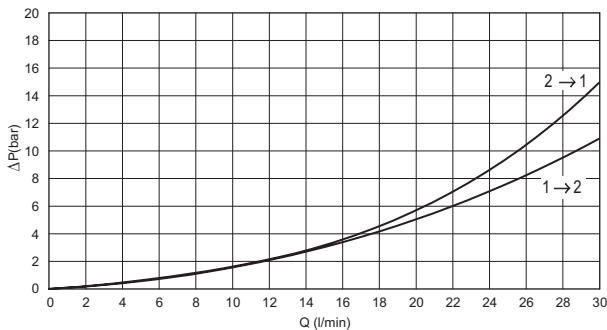

Fluid used: mineral based oil with viscosity 32 mm²/s at 40°C.

OPERAT. FORCE ON THE PUSH BUTTON

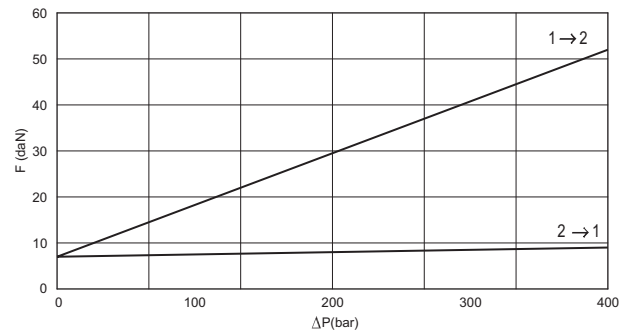

Fluid used: mineral based oil with viscosity 32 mm²/s at 40°C.

ORDERING CODE

