



**BREVINI<sup>®</sup>**

*Motion Systems*

**JMPIAZ - JMPID Electronic remote current control unit**

**Technical Catalogue**

January  
**2018**

*web edition*



JMPIAZ joystick is a strong and compact device, whose ergonomic shape is handily organised.

The person present system switch and many other remote control functions can be implemented and operated conveniently. It is developed to meet mobile machinery market requirements, where it is increasingly important to handle the power transmission supply with integrated remote control.

JMPIAZ is simple to fit and replace and is made up of a standard module with two proportional axes and a hand grip that can house several combinations of other proportional axes (up to 4) and ON/OFF outputs.

This joystick allows all the electronic features of ramp generator function, electronic flow adjustment, and dead band compensation (only for proportional axes).

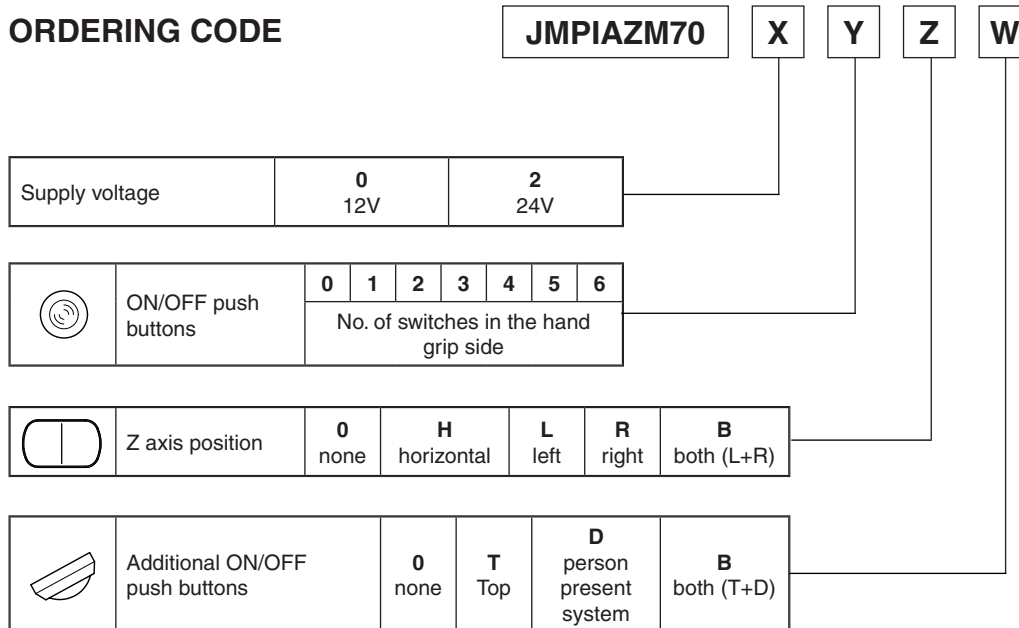

ON/OFF push buttons (Y)  
and Z axis position (Z)

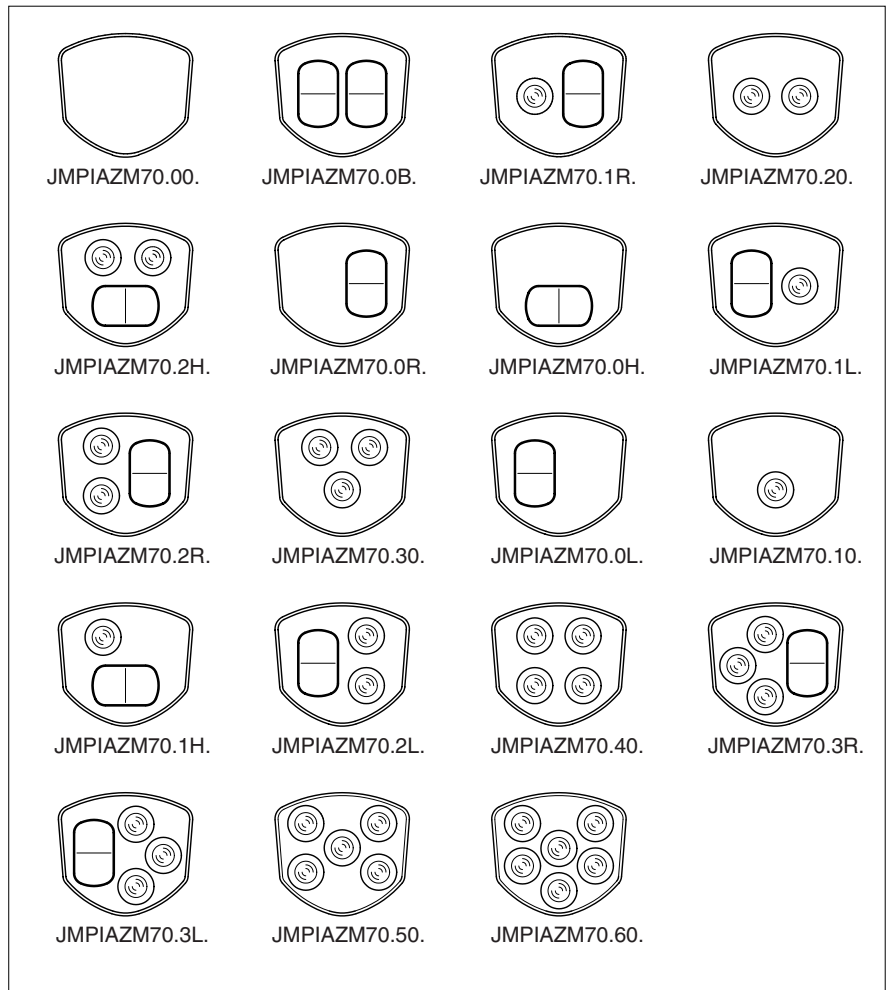

Additional ON/OFF push  
buttons (W)

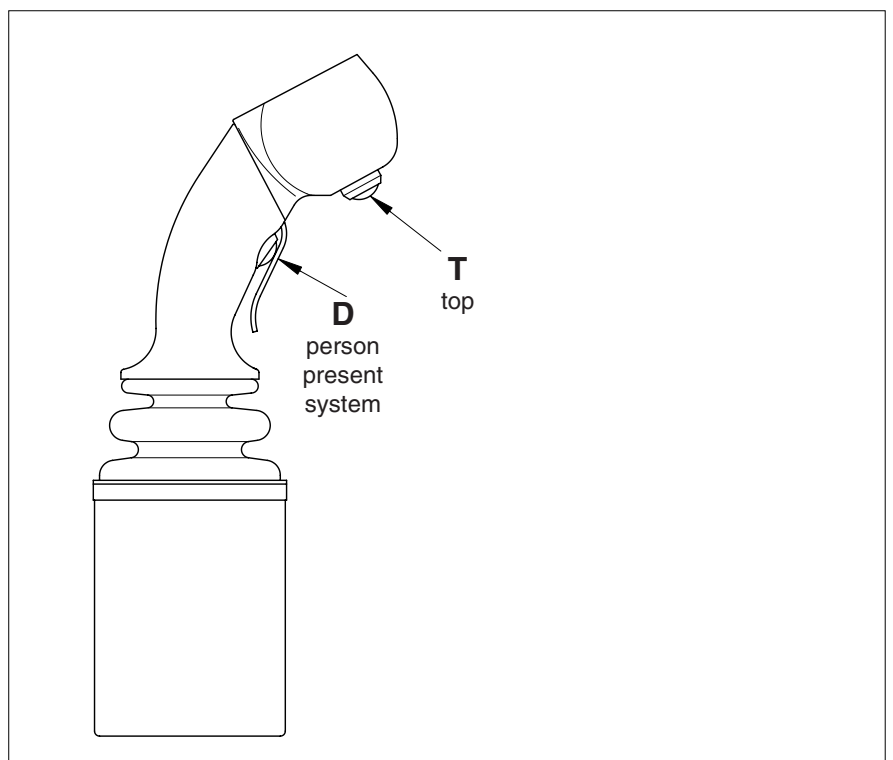

Dimensions and electrical details

**JMPIAZM70240D**

- 4 ON/OFF push buttons in hand grip side
- NO Z axis
- deadman push button

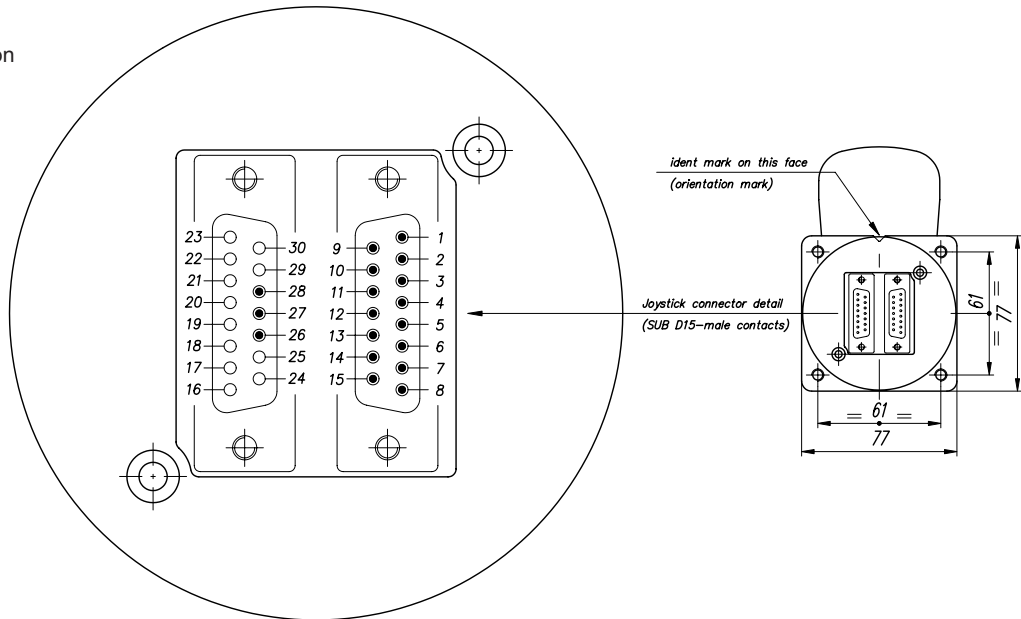

JMPIAZM70040D (12 V)  
JMPIAZM70240D (24 V)

- 1 = U-
- 2 = A / B common X axis
- 3 = A output control, X axis
- 4 = B output control, X axis
- 5 = B output control, Y axis
- 6 = A output control, Y axis
- 7 = A / B common Y axis
- 8 = U+
- 9 = "A" port, directional output (max. load 30 mA)
- 10 = "B" port, directional output (max. load 30 mA)
- 11 = US+ ( Safety output )
- 12 = U S+ ( Safety in )
- 13 = on-off output (max. load 30 mA)
- 14 = "B" port, directional output (max. load 30 mA)
- 15 = "A" port, directional output (max. load 30 mA)
- 16 = ( free )
- 17 = ( free )
- 18 = ( free )
- 19 = ( free )
- 20 = ( free )
- 21 = ( free )
- 22 = ( free )
- 23 = ( free )
- 24 = ( free )
- 25 = ( free )
- 26 = on-off output (max. load 30 mA)
- 27 = on-off output (max. load 30 mA)
- 28 = on-off output (max. load 30 mA)
- 29 = ( free )
- 30 = ( free )

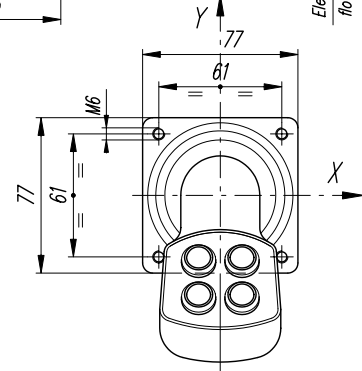
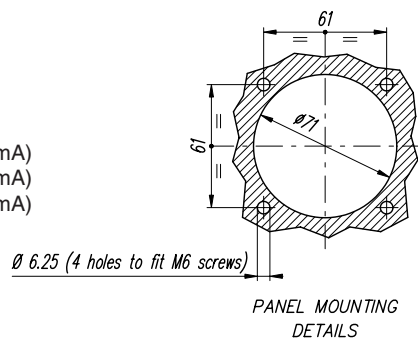
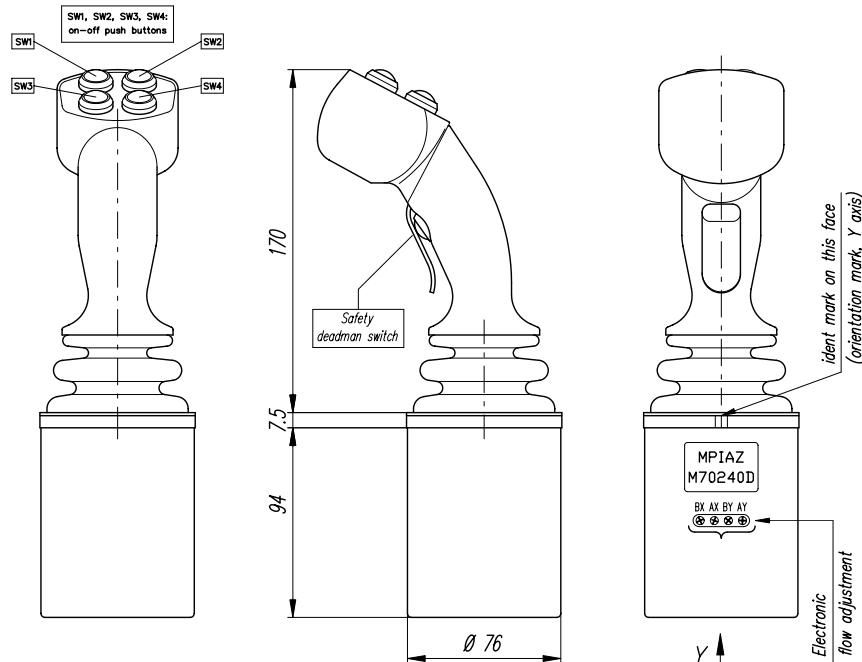

Electrical system

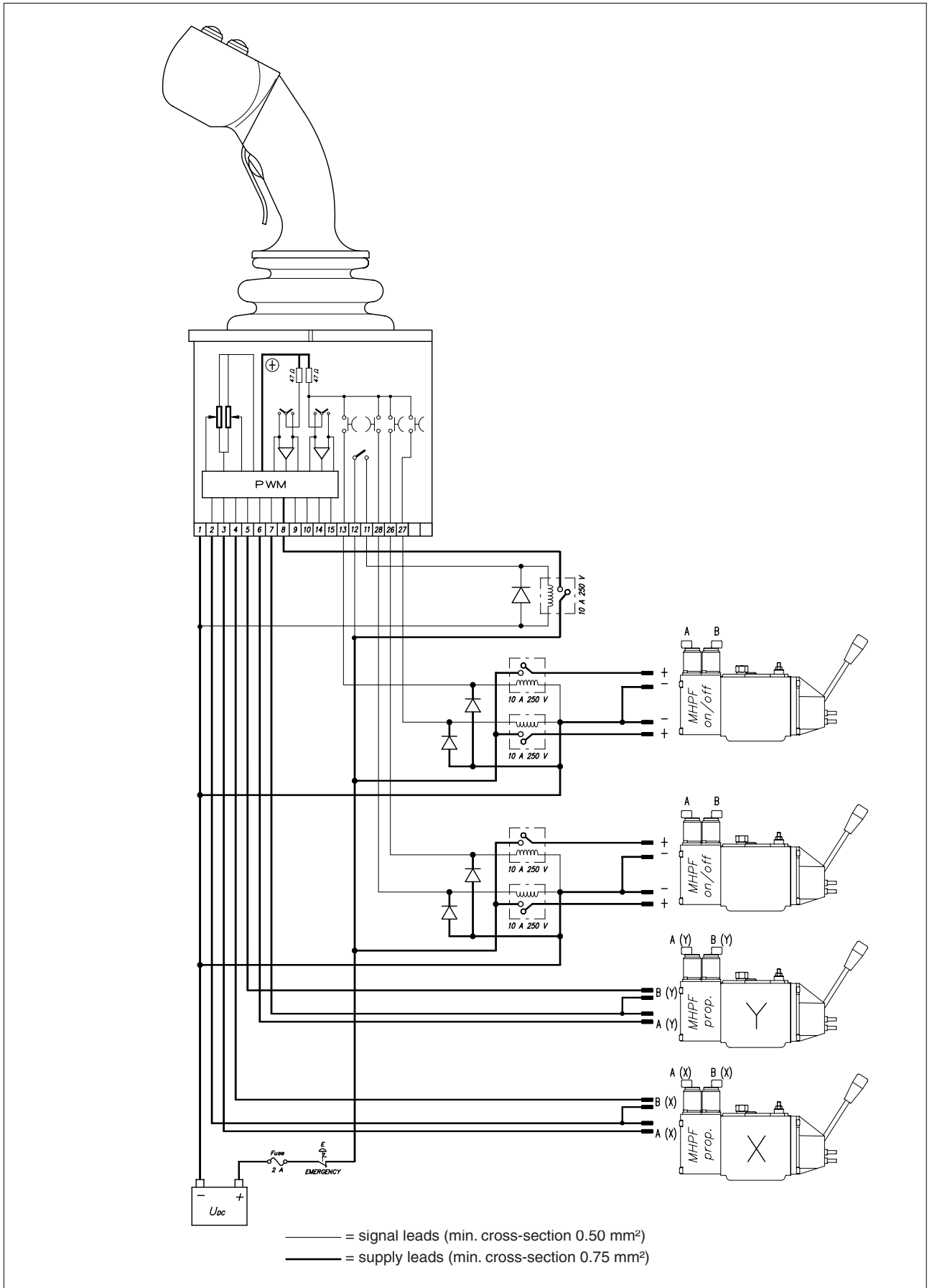

Dimensions and electrical details

### JMPIAZM7002LD (12V) JMPIAZM7022LD (24V)

Ident mark on this face  
(orientation mark)

Ident mark on this face  
(orientation mark)

- 2 ON/OFF push buttons in hand grip side
- Z axis in left position
- deadman push button

Ident mark on this face  
(orientation mark)

### JMPIAZM7000LD (12V) JMPIAZM7020LD (24V)

Ident mark on this face  
(orientation mark)

Ident mark on this face  
(orientation mark)

- NO push buttons in hand grip side
- Z axis in left position
- deadman push button

Ident mark on this face  
(orientation mark)

<p>1 = U-</p> <p>2 = A / B common X axis</p> <p>3 = A output control, X axis</p> <p>4 = B output control, X axis</p> <p>5 = B output control, Y axis</p> <p>6 = A output control, Y axis</p> <p>7 = A / B common Y axis</p> <p>8 = U+</p> <p>9 = "A" port, directional output (max. load 30 mA)</p> <p>10 = "B" port, directional output (max. load 30 mA)</p> <p>11 = Safety switch on</p> <p>12 = Common safety switch</p> <p>13 = ( free )</p> <p>14 = "B" port, directional output (max. load 30 mA)</p> <p>15 = "A" port, directional output (max. load 30 mA)</p>	<p>16 = U-</p> <p>17 = A / B common Z axis</p> <p>18 = A output control, Z axis</p> <p>19 = B output control, Z axis</p> <p>20 = ( free )</p> <p>21 = ( free )</p> <p>22 = ( free )</p> <p>23 = U+</p> <p>24 = "A" port, directional output (max. load 30 mA)</p> <p>25 = "B" port, directional output (max. load 30 mA)</p> <p>26 = switch on</p> <p>27 = ( free )</p> <p>28 = switch on</p> <p>29 = ( free )</p> <p>30 = ( free )</p>
---	---

<p>1 = U-</p> <p>2 = A / B common X axis</p> <p>3 = A output control, X axis</p> <p>4 = B output control, X axis</p> <p>5 = B output control, Y axis</p> <p>6 = A output control, Y axis</p> <p>7 = A / B common Y axis</p> <p>8 = U+</p> <p>9 = "A" port, directional output (max. load 30 mA)</p> <p>10 = "B" port, directional output (max. load 30 mA)</p> <p>11 = Safety deadman switch on</p> <p>12 = Common safety deadman switch</p> <p>13 = ( free )</p> <p>14 = "B" port, directional output (max. load 30 mA)</p>	<p>15 = "A" port, directional output (max. load 30 mA)</p> <p>16 = U-</p> <p>17 = A / B common Z axis</p> <p>18 = A output control, Z axis</p> <p>19 = B output control, Z axis</p> <p>20 = ( free )</p> <p>21 = ( free )</p> <p>22 = ( free )</p> <p>23 = U+</p> <p>24 = "A" port, directional output (max. load 30 mA)</p> <p>25 = "B" port, directional output (max. load 30 mA)</p> <p>26 = ( free )</p> <p>27 = ( free )</p> <p>28 = ( free )</p> <p>29 = ( free )</p> <p>30 = ( free )</p>
--	--

Electrical system

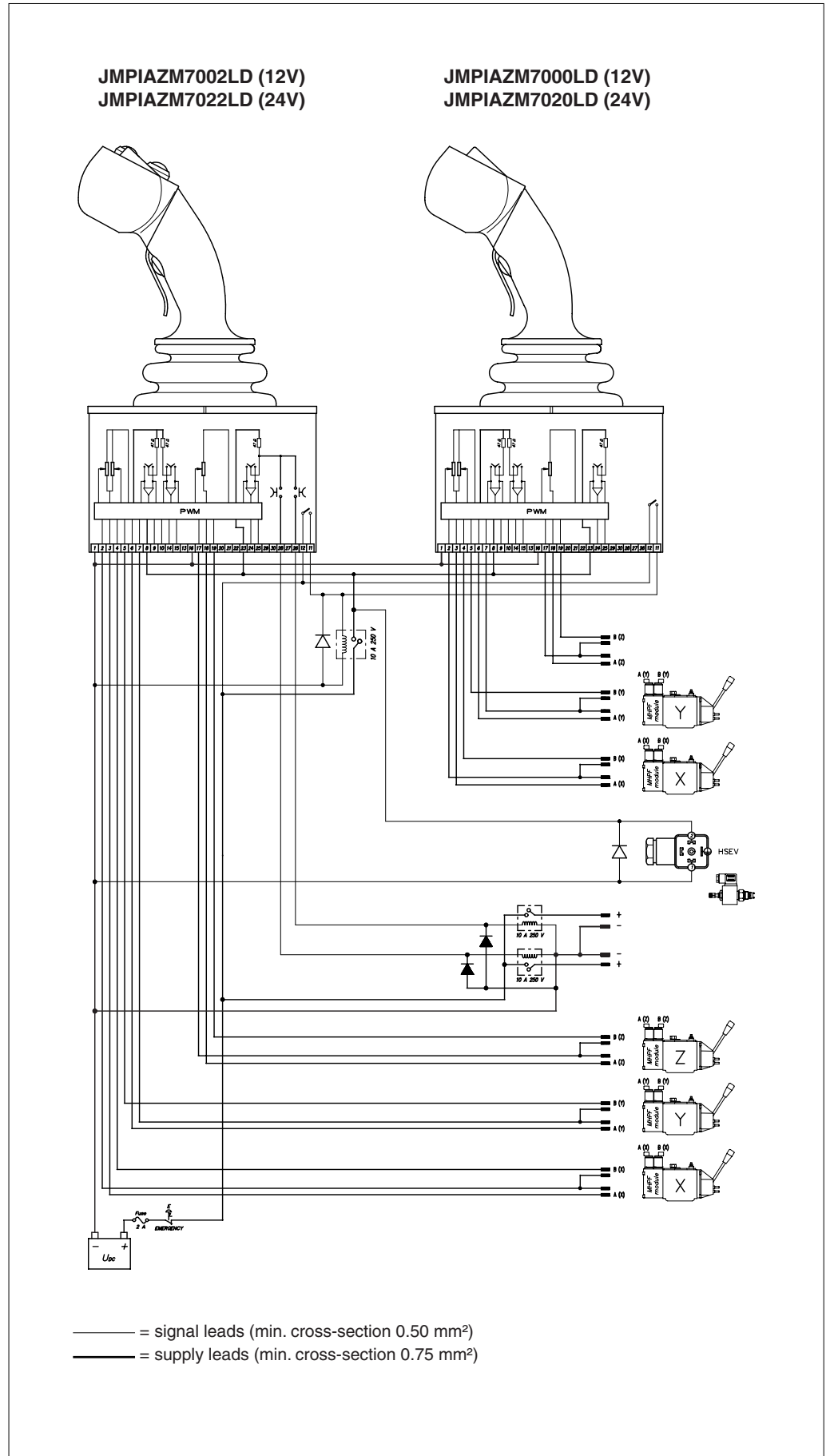

JMPID joystick is a strong and compact device, whose ergonomic shape is handily organised.

The person present system switch and many other remote control functions can be implemented and operated conveniently. It is developed to meet mobile machinery market requirements, where it is increasingly important to handle the power transmission supply with integrated remote control.

JMPID is simple to fit and replace and is made up of a standard module with two proportional axes and a hand grip that can house several combinations of other ON/OFF outputs.

This joystick allows all the electronic features of ramp generator function, electronic flow adjustment, and dead band compensation (only for proportional axes).



K handle  
(no switch)

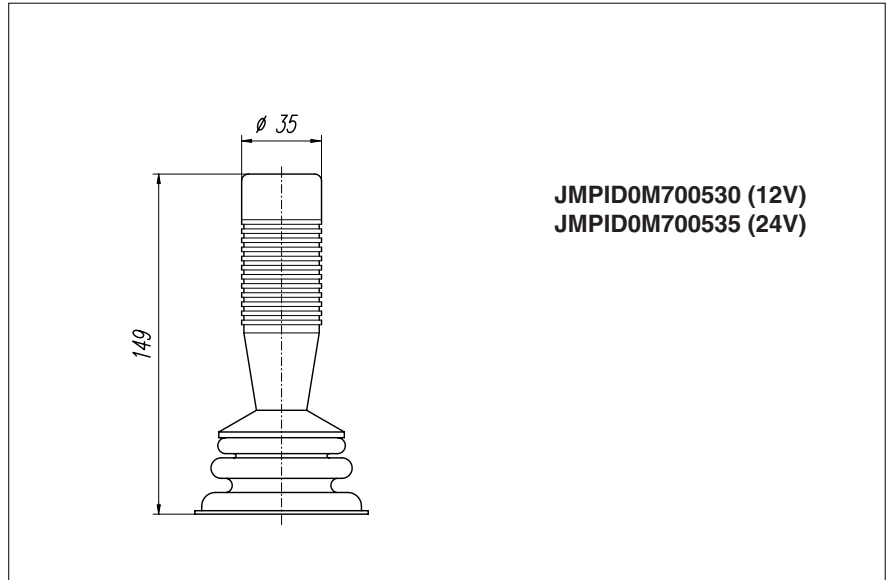

H handle  
(rocker switch)

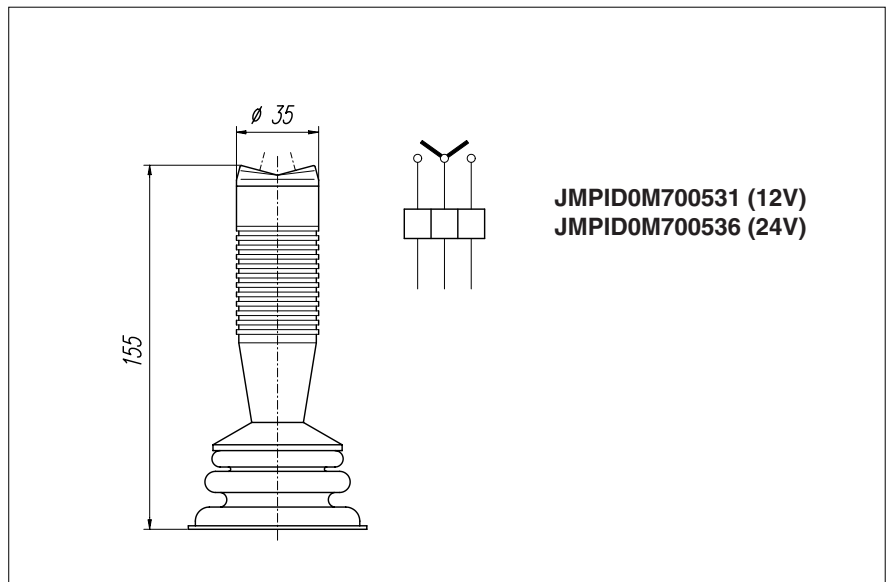

L handle  
(deadman switch)

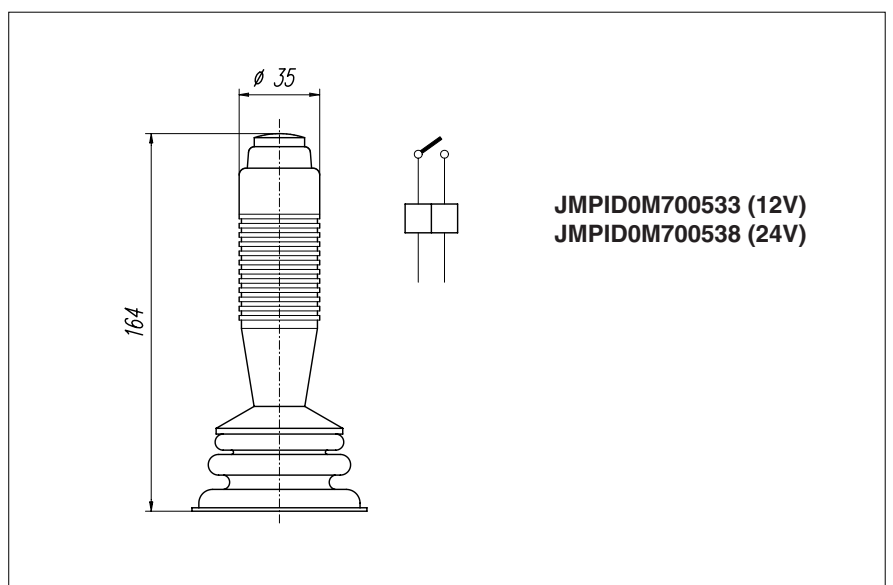

Dimensions and electrical details

**“K” Handle (no switch)**  
**JMPID0M700530 (12V)**  
**JMPID0M700535 (24V)**

- 1 = U-
- 2 = A / B common X axis
- 3 = A output control, X axis
- 4 = B output control, X axis
- 5 = B output control, Y axis
- 6 = A output control, Y axis
- 7 = A / B common Y axis
- 8 = U+
- 9 = “A” port, directional output (max. load 30 mA), X axis
- 10 = “B” port, directional output (max. load 30 mA), X axis
- 11 = ( free )
- 12 = ( free )
- 13 = ( free )
- 14 = “B” port, directional output (max. load 30 mA), Y axis
- 15 = “A” port, directional output (max. load 30 mA), Y axis

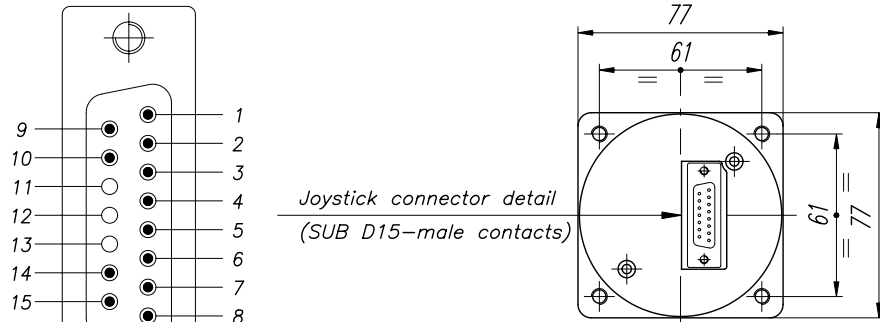

Joystick connector detail  
(SUB D15-male contacts)

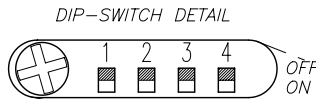
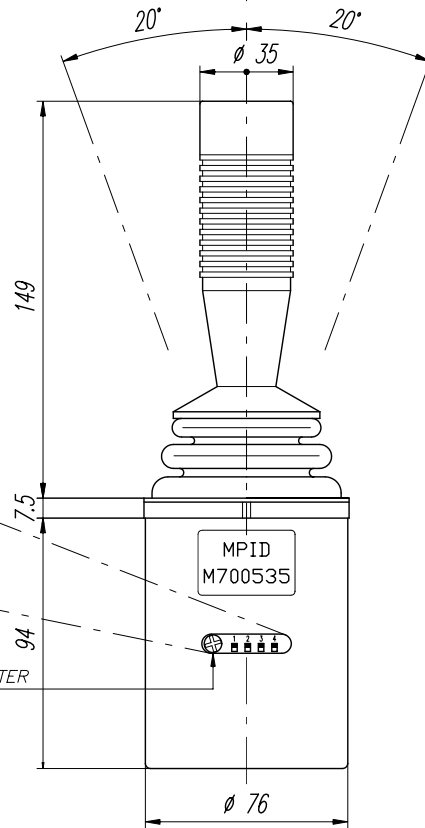

TRIMMING POTENTIOMETER  
K POSITION

PANEL MOUNTING DETAILS

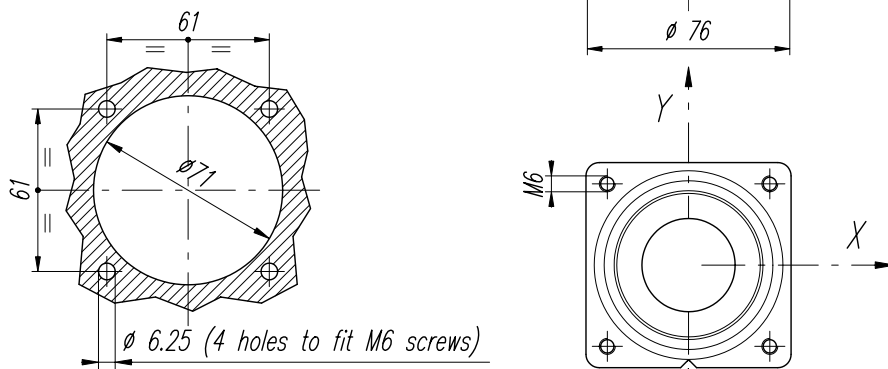

ident mark on this face  
(orientation mark)

Electrical system

“K” Handle (no switch)  
 JMPID0M700530 (12V)  
 JMPID0M700535 (24V)

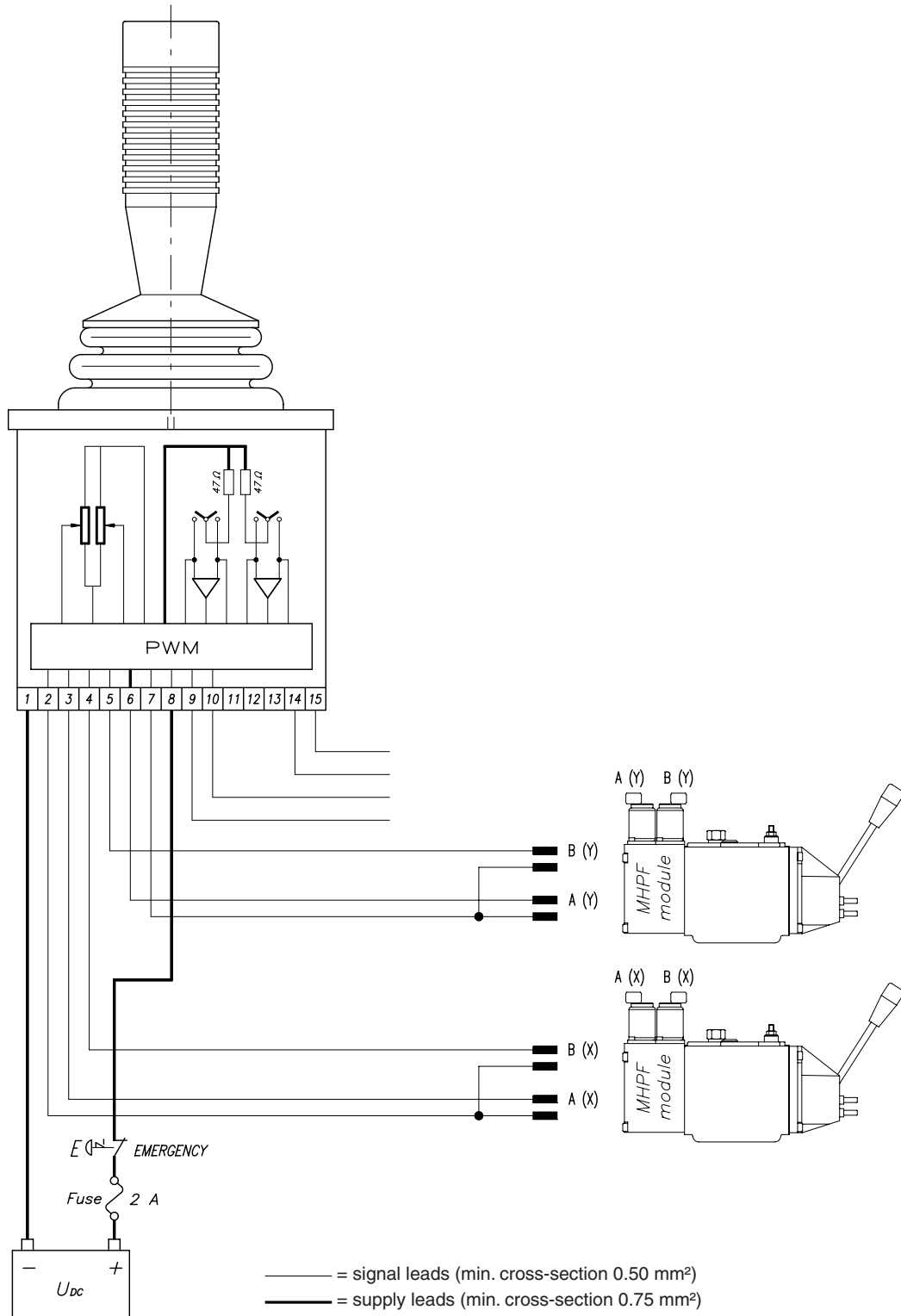

Dimensions and electrical details

**“H” Handle (rocker switch)**  
**JMPID0M700531 (12V)**  
**JMPID0M700536 (24V)**

- 1 = U-
- 2 = A / B common X axis
- 3 = A output control, X axis
- 4 = B output control, X axis
- 5 = B output control, Y axis
- 6 = A output control, Y axis
- 7 = A / B common Y axis
- 8 = U+
- 9 = “A” port, directional output (max. load 30 mA), X axis
- 10 = “B” port, directional output (max. load 30 mA), X axis
- 11 = Switch on (max. load = 30 mA)
- 12 = Common terminal switch on/off/on
- 13 = Switch on (max. load = 30 mA)
- 14 = “B” port, directional output (max. load 30 mA), Y axis
- 15 = “A” port, directional output (max. load 30 mA), Y axis

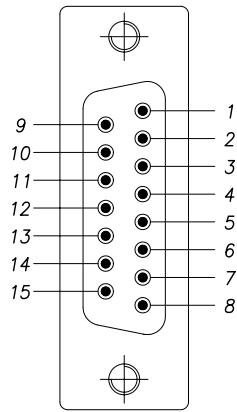

Joystick connector detail  
(SUB D15--male contacts)

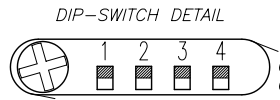
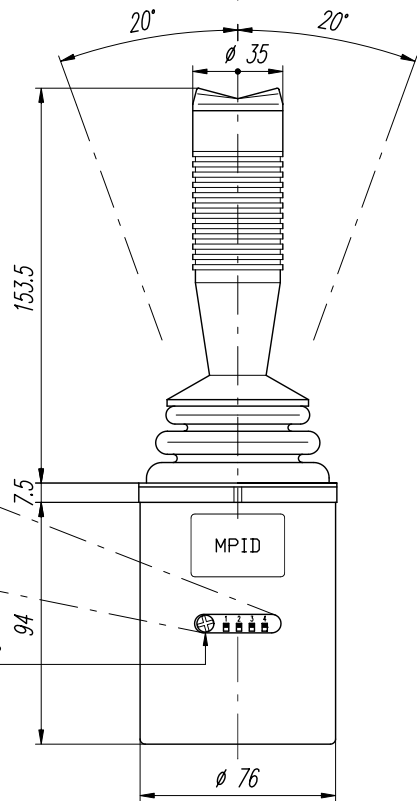
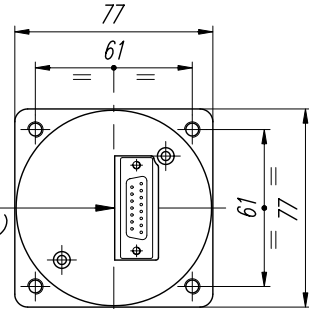

TRIMMING POTENTIOMETER  
K POSITION

PANEL MOUNTING DETAILS

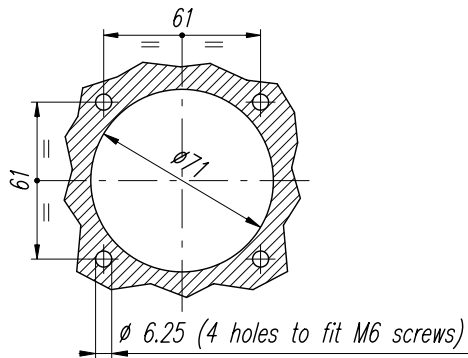

ident mark on this face  
(orientation mark)

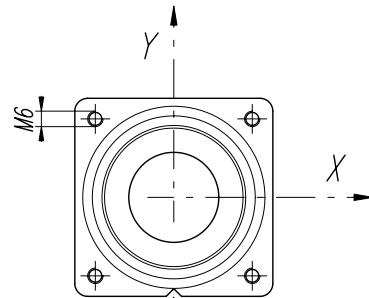

Electrical system

“H” Handle (rocker switch)  
 JMPID0M700531 (12V)  
 JMPID0M700536 (24V)

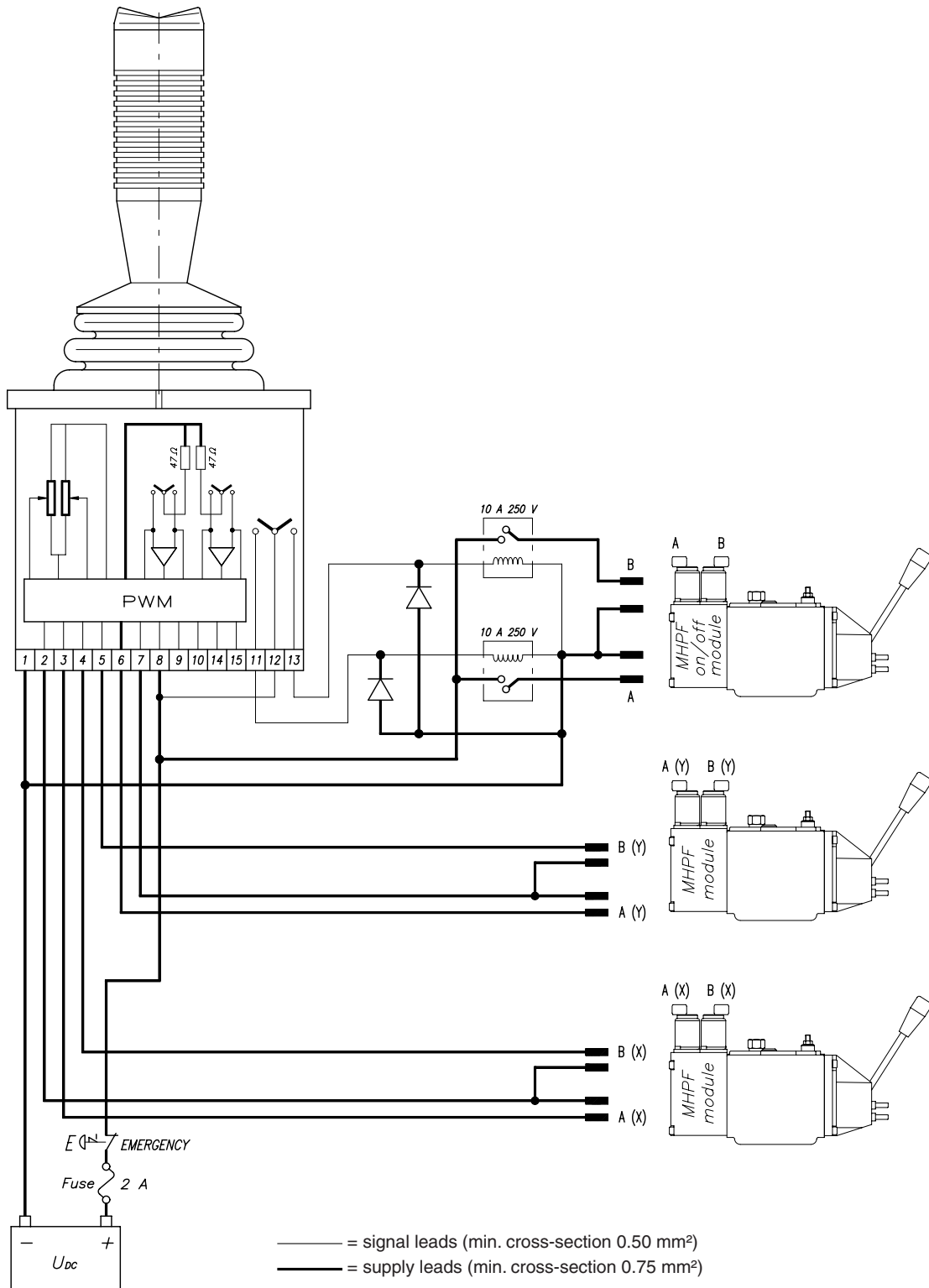

Dimensions and electrical details

**"L" Handle (deadman switch)**  
**JMPID0M700533 (12V)**  
**JMPID0M700538 (24V)**

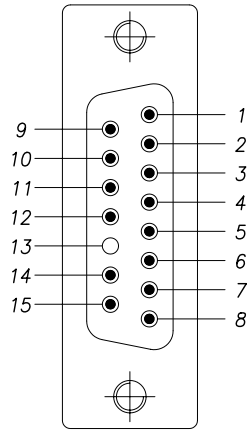

- 1 = U-
- 2 = A / B common X axis
- 3 = A output control, X axis
- 4 = B output control, X axis
- 5 = B output control, Y axis
- 6 = A output control, Y axis
- 7 = A / B common Y axis
- 8 = U+
- 9 = "A" port, directional output (max. load 30 mA), X axis
- 10 = "B" port, directional output (max. load 30 mA), X axis
- 11 = Switch on (max. load = 30 mA)
- 12 = Common terminal switch on/off
- 13 = ( free )
- 14 = "B" port, directional output (max. load 30 mA), Y axis
- 15 = "A" port, directional output (max. load 30 mA), Y axis

Joystick connector detail  
(SUB D15-male contacts)

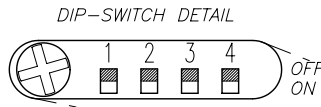
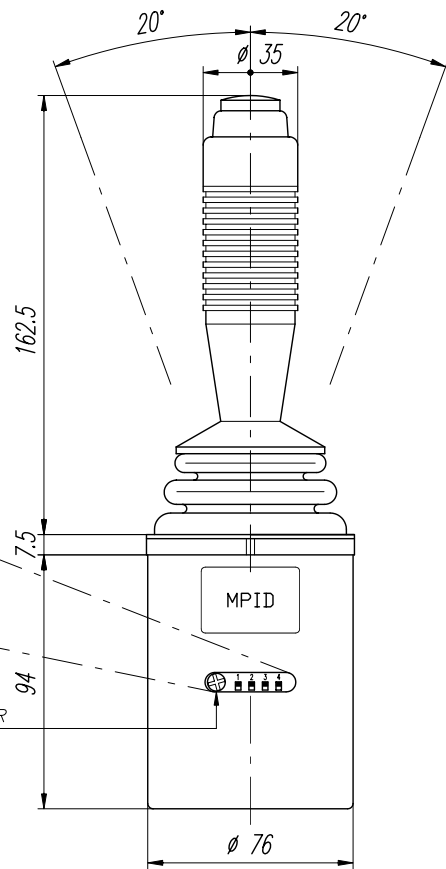
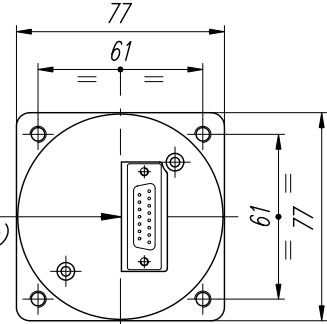

TRIMMING POTENTIOMETER  
K POSITION

PANEL MOUNTING DETAILS

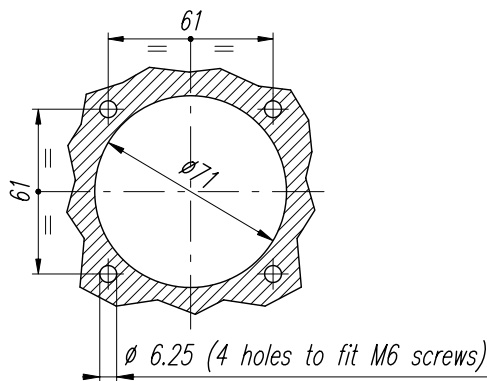

ident mark on this face  
(orientation mark)

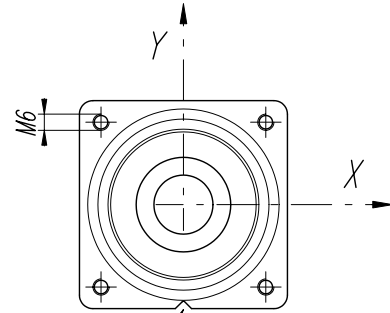

Electrical system

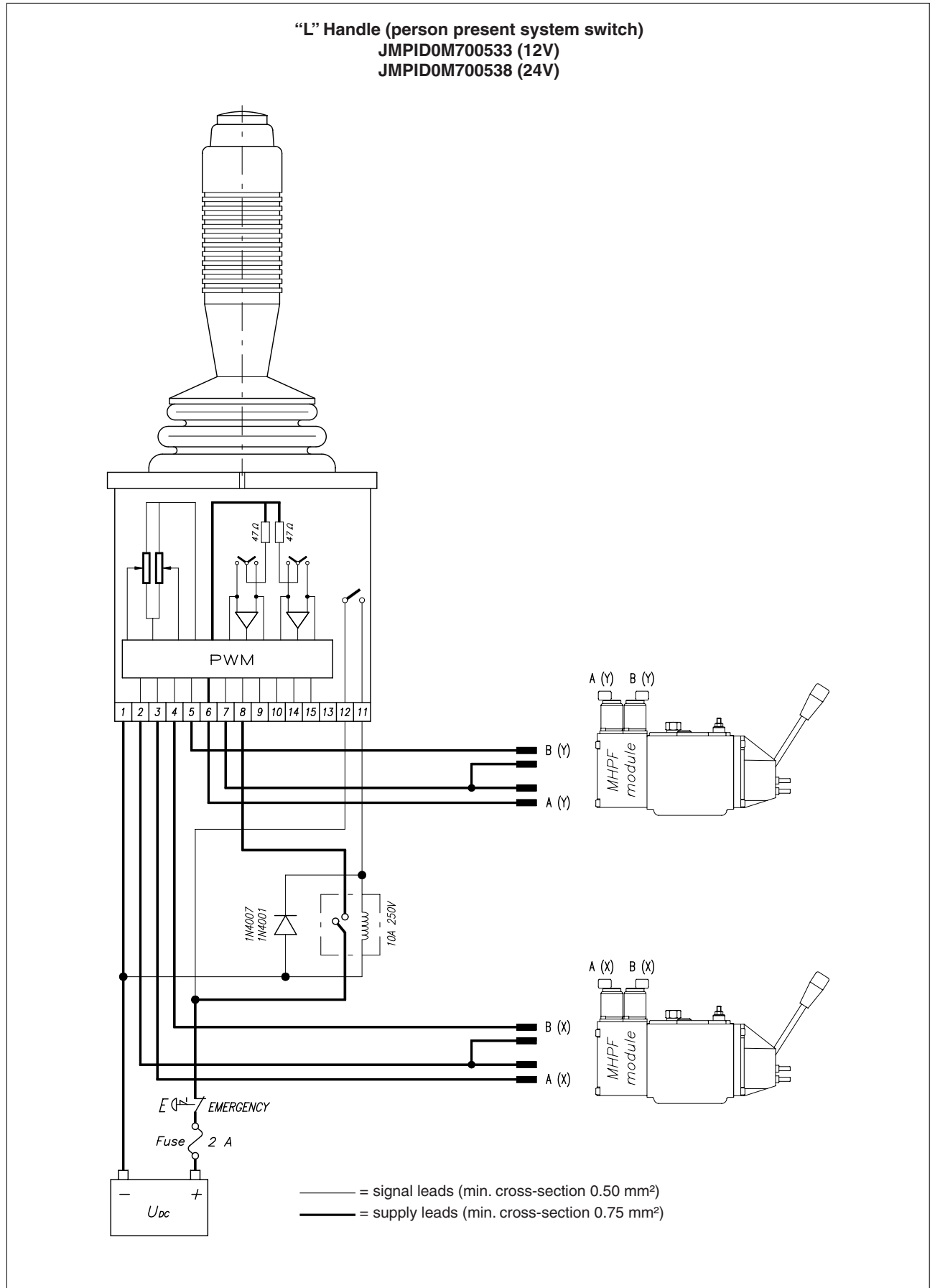



**BREVINI<sup>®</sup>**

*Motion Systems*

Rev.01

**Dana Motion Systems Italia S.r.l.**

Fluid Power Division

Sede operativa: Via Giulio Natta 1, 42124 Reggio Emilia - Italy  
Tel: +39.0522.270711 - Fax: +39.0522.505856

Sede legale: Via Luciano Brevini 1/A, 42124 Reggio Emilia - Italy  
Tel: +39.0522.9281 - Fax: +39.0522.928300

[www.dana.com/brevini](http://www.dana.com/brevini) - [dana.re@dana.com](mailto:dana.re@dana.com)

