

BA130... Low / HIGH PRESSURE UNITS

The low/high pressure groups are usually employed in hydraulic systems fed by dual pumps that form a single pressure circuit. The main feature of this system consists in being able to set a pressure value in correspondence of which one of the two pumping sections is changed over to drain.

These groups are fitted with an adjustable maximum pressure valve to protect the hydraulic system.

2 pressure adjustment ranges are available for the exclusion valve, which is fitted with a steel seat, while the maximum pressure valve type CMP10 is available with 3 adjustment ranges.

Minimum permissible setting pressure depending on the spring: see cartridge valve type CMP10.

The series connection modular small block (BC532) or the parallel connection type (BC530) with blanking plate (BC540) and the solenoid valve should be ordered separately.

For the subplate mounting ordering code see "Subplates" chapter; whilst for the valve ordering code see "Directional control valves" chapter.

The CETOP5/NG10 connector blocks have 3 rods.

Max. flow	130 l/min
Max. operating pressure	320 bar
Fluid viscosity	10 ÷ 500 mm ² /s
Fluid temperature	-25°C ÷ 75°C
Ambient temperature	-25°C ÷ 60°C
Max. contamination level	class 10 in accordance with NAS 1638 with filter $\beta_{25} \geq 75$
Weight	8 Kg

PRESSURE DROPS

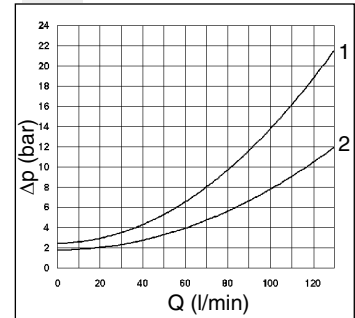

Curve	1 = P1 → T
	2 = P1 → P

BA130...

BA10...	CAP. X • 3
CMP10...	CAP. VII • 30
BSC569...	CAP. X • 7
BC530/32...	CAP. VII • 26
BC540...	CAP. VII • 25
CETOP 5/NG10	CAP. I • 33
ADP5E...	CAP. I • 41

ORDERING CODE

BA	Low/high pressure base
130	Capacity l/min
U*	Double pump exclusion valve setting 2 = 20 ÷ 90 bar 3 = 50 ÷ 190 bar
C	Type of adjustment: grub screw
*	Max. pressure valve setting 1 = max. 50 bar 2 = max. 150 bar 3 = max. 320 bar
00	No variant
1	Serial No.

MODULE ORDERING CODE

BA	Subplate mounting
10	CETOP 5/NG10
**	Type of module: 62 = side CETOP interface 68 = with upper threaded connectors
00	No variant
1	Serial No.

OVERALL DIMENSIONS AND HYDRAULIC SYMBOL

Fixing screws M6x100 UNI 5931

Pay attention please, max tightening torque for manometer (M2): 35 Nm / 3,5 Kgm

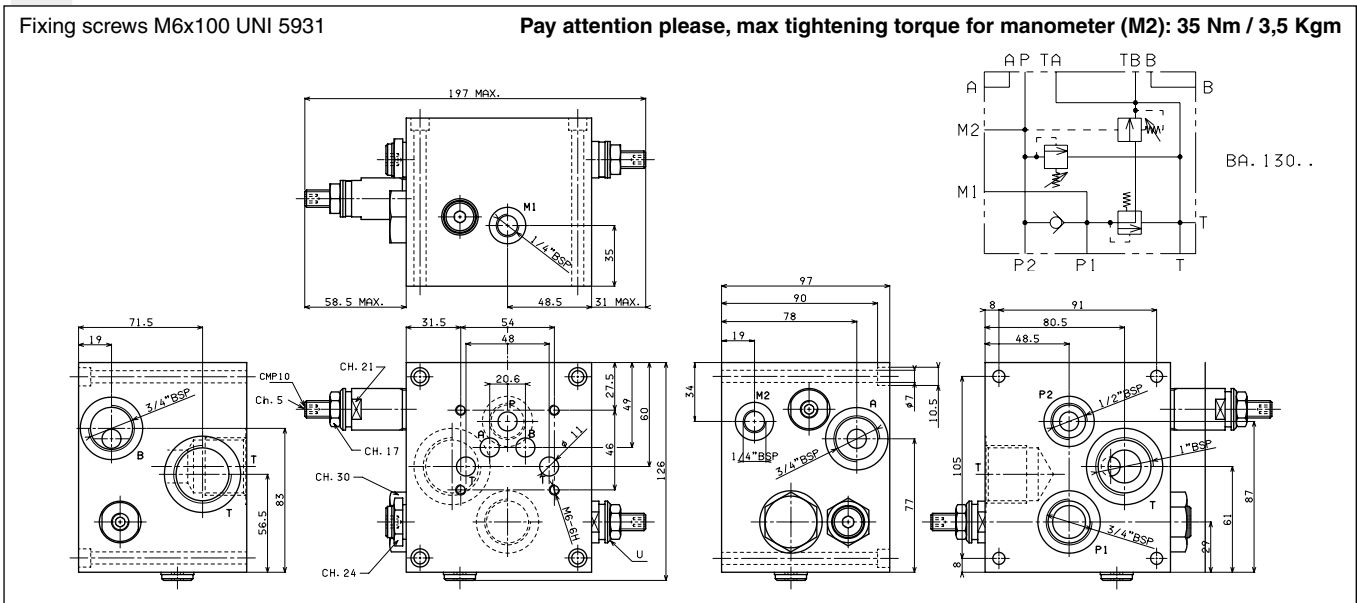

10

BA130... Low / HIGH PRESSURE UNITS

OVERALL DIMENSIONS AND HYDRAULIC SYMBOLS

SIDE MOUNTING FOR SINGLE SOLENOID VALVE CETOP5/NG10 (CONNECTOR BLOCK BA1062)

Fixing screws M10x80 UNI 5931

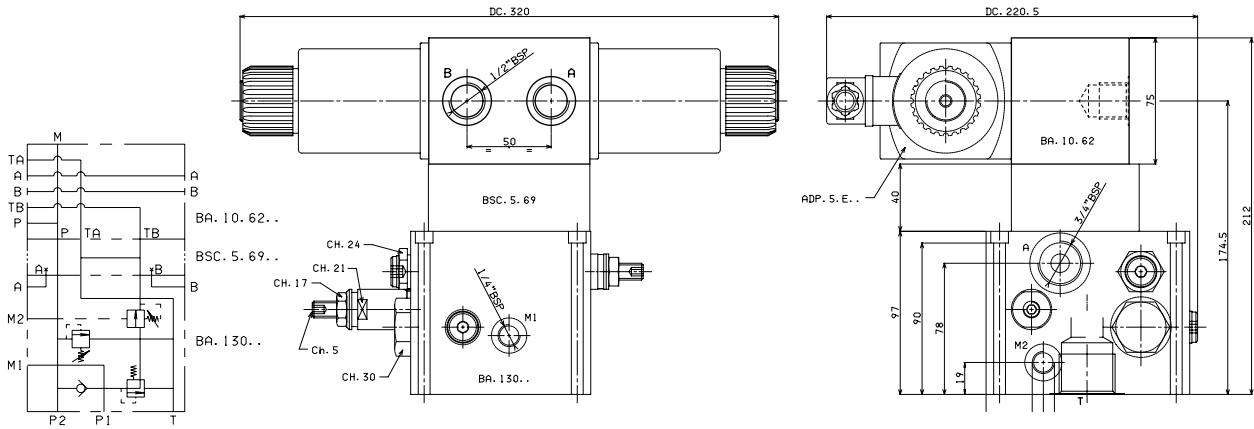

UPPER MOUNTING FOR SINGLE SOLENOID VALVE CETOP5/NG10

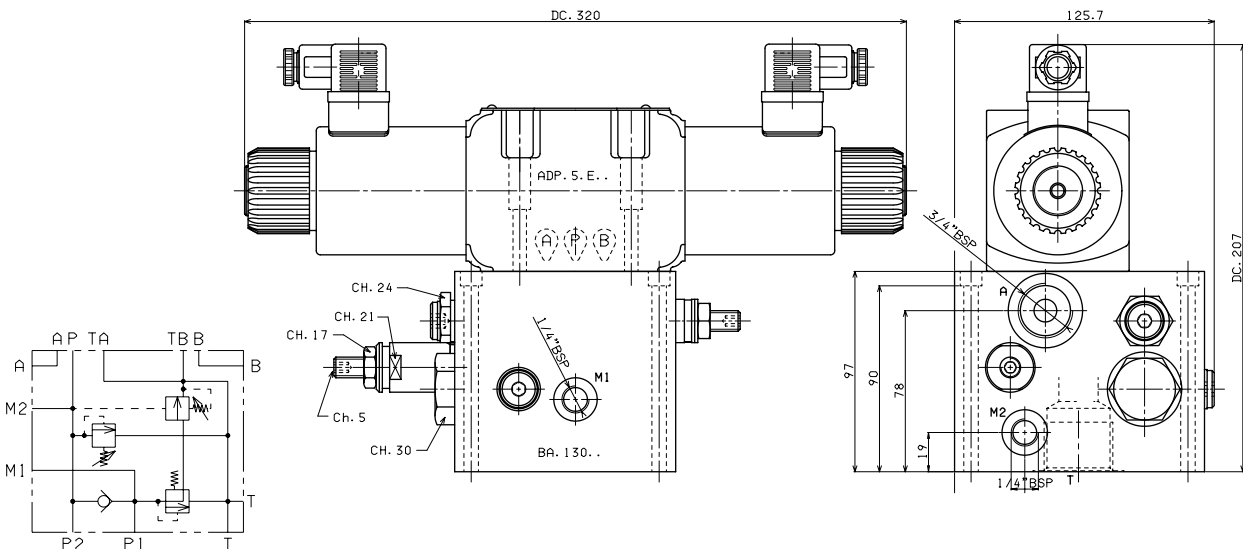

MOUNTING WITH THREADED CONNECTORS (CONNECTOR BLOCK BA1068)

Fixing screws M10x45 UNI 5931

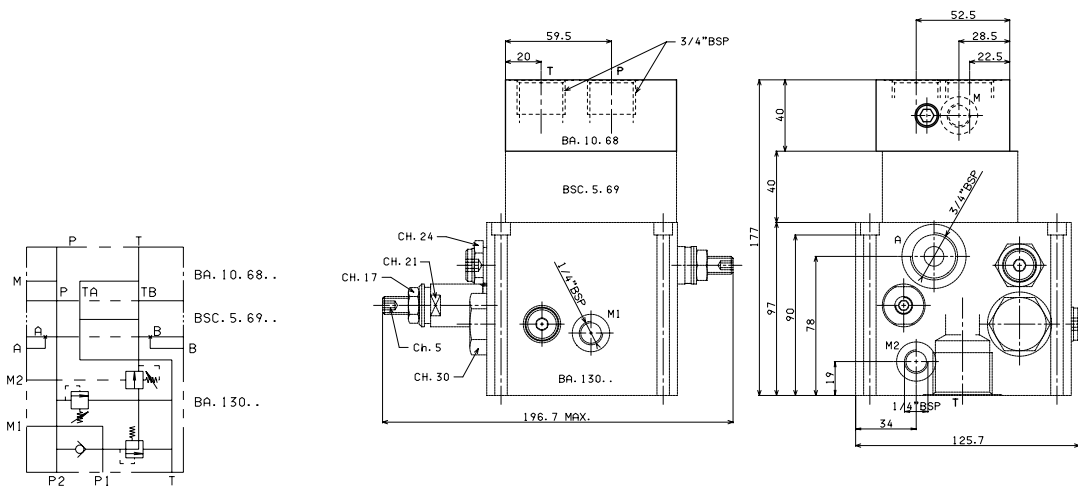

10

BA130... Low / HIGH PRESSURE UNITS

OVERALL DIMENSIONS AND HYDRAULIC SYMBOL

MULTIPLE MOUNTING WITH MODULAR COMPONENT CONNECTOR BLOCKS CONNECTED IN SERIES OR PARALLEL CETOP5/NG10

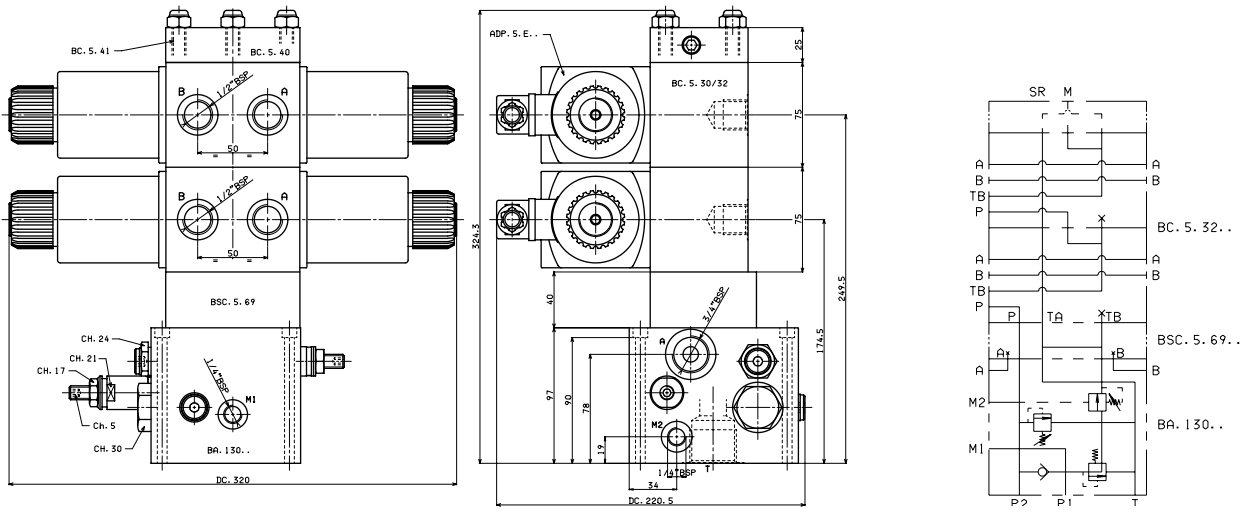

BSC569... TRANSFORMATION MOUNTING CETOP 5 INTERFACE TO MODULAR COMPONENT BC5...

- BSC** Modular component subplate
- 5** CETOP 5/NG10
- 69** Type of module: to modular component BC5
- 00** No variant
- 1** Serial No.

Fixing screws M6x35 UNI 5931
Weight 2,1 Kg

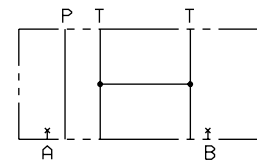

BSC. 5. 69. .

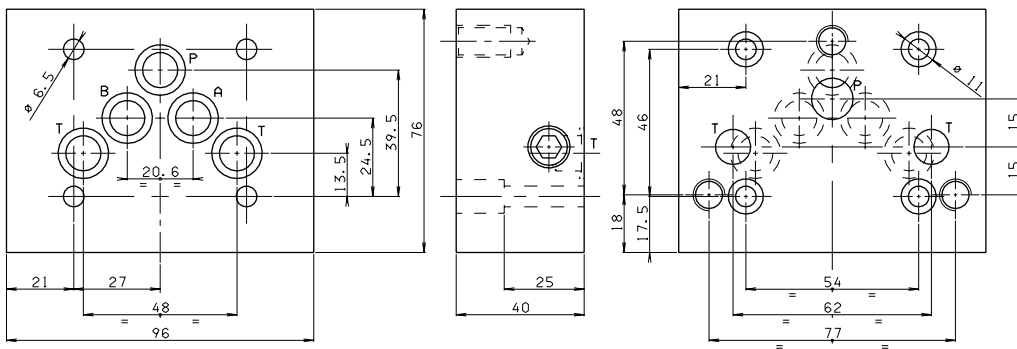

10