

CXDH3 / CDH3 (variants)

"LF", "LR" AND "LV" VARIANTS - EMERGENCY CONTROL LEVER

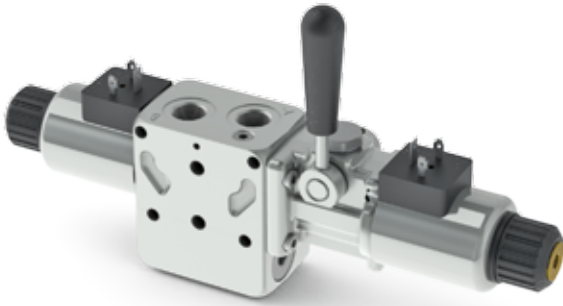

1

Thanks to his flexibility, the component is designed to be inserted between the valve body and the spool, providing total interchangeability between the different types of solenoid body valves manufactured by Dana Brevini (*). The control can be used as an emergency device in the event of power cuts.

HYDRAULIC SYMBOL

Var. LF/LR lever on the side A:

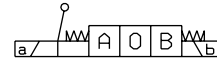

Var. LV lever on the side B:

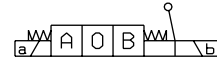

Spool 01  available on request

Max operating pressure port T	dynamic	160 bar
	static	210 bar
Mounting type Var. LF/LR	C - B - F - H	
Mounting type Var. LV	C-A	
Spools type	01-02-03-04 16-17-66	
Weight with single solenoid	3.34 kg	
Weight with double solenoid	3.73 kg	

* Max flow of proportional valves can be reduced compared to versions without emergency control lever when electrical operated. Max flow of proportional valves lever operated is increased compared to the max flow given when valves are electrical operated.

**LF Variant
(CXDH3 / CDH3)**

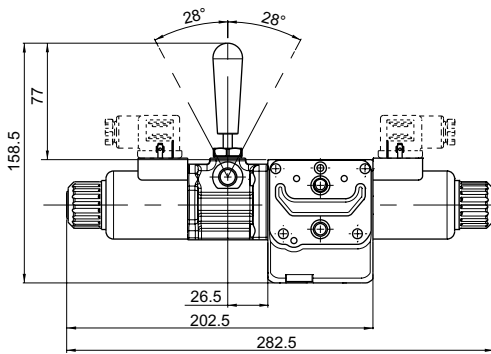

**LF Variant
Body L
(CXDH3)**

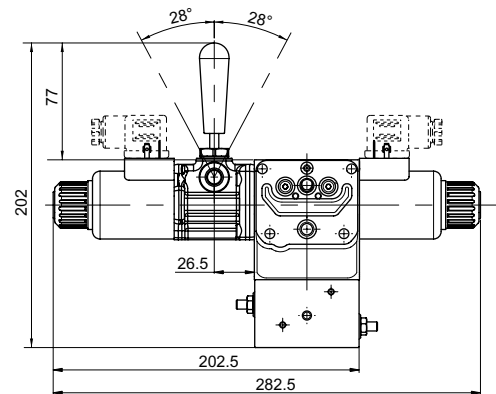

**LR Variant
(CXDH3 / CDH3)**

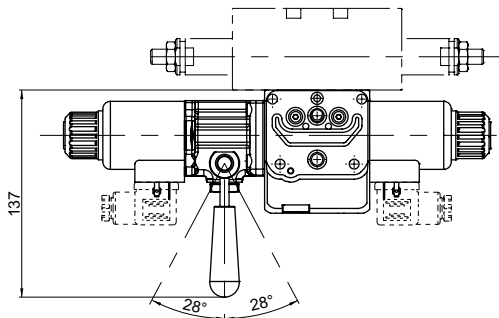

**LR Variant
M Body
(CXDH3)**

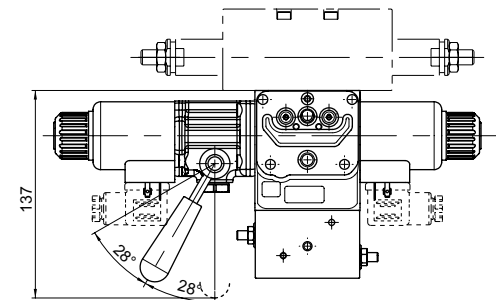

**LV Variant
(CXDH3 / CDH3)**

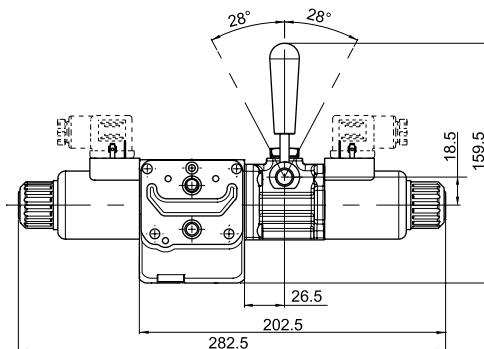

USE OF HSIF INTERFACE WITH MODULAR VALVES CXDH3/CDH3, WITH EMERGENCY LEVER

Distributor HPV41 right (DX, standard)

- Order modular valves CXDH3/CDH3 variant LV, with emergency lever on the side B

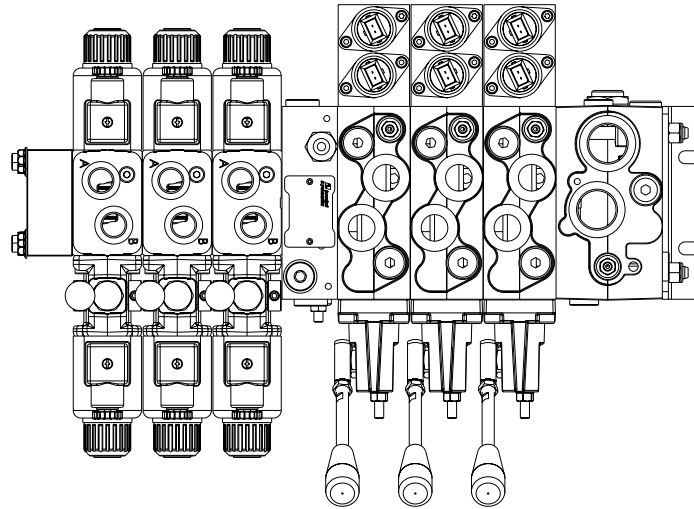

1

Distributor HPV41 left (SX)

- Order modular valves CXDH3/CDH3 variants LF / LR, with emergency lever on side A

- In this case it is not possible to mount the modular valve CXDH3/CDH3 variant LF / LR as the first element after HSIF interface.

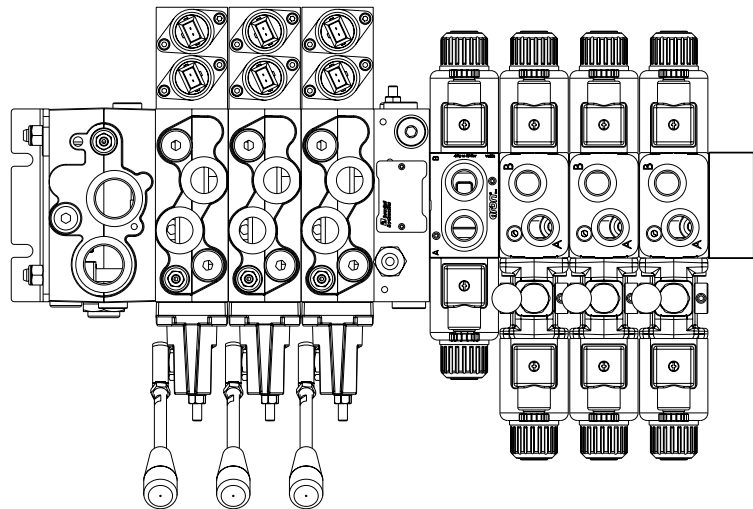

OTHER VARIANTS

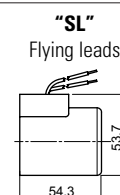
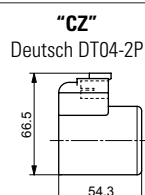
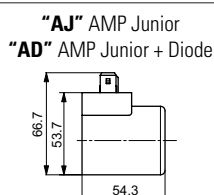
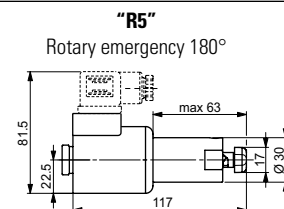
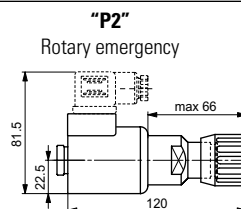
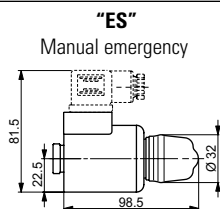

Emergency P2 and P5, tightening torque max. 6÷9 Nm (CH n. 22)